



GAP90™

Fire Door Head/Jamb Gap Solutions—Up To 90 Minutes

PRODUCT CUT SHEET

UL Certified for Head/Jamb Gaps
— Measuring Over 1/8", and up to 5/16".



- 90-Minute Rated — for Use on UL10B and UL10C Wood or Hollow Metal Fire Doors
- Restricts the Passage of Smoke
- Non-Handed
- Available in 36", 48", 84" and 96" Lengths
- An NGP Strike Shim (9275 or 9225) may also be Required for Proper Latchbolt Engagement
- A Mounting Bracket (600D-28) is Recommended when using Parallel Arm Closers

GAP90™

Requires Installation of ALL Components:
9945, 9400, 5075CL

GAP90DKB™

Requires Installation of ALL Components:
9945, 9400DKB, 5075B

GAP90W™

Requires Installation of ALL Components:
9945, 9400W, 5075W

9945

Steel Stop Extender

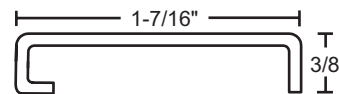

- 16-Gauge, Gray Primer Finish
- Furnished With #10 X 1" TEK SMS
- Patent No.: US9,273,510B2

5075

Self-Adhesive TPE Seal

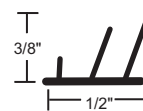

*Anti-Microbial not available in clear

5075B	BROWN
5075CL	CLEAR*
5075W	WHITE

9400

NGP-Edge® Intumescent Seal With PVC Cover



Anti-Microbial



9400	GRAY
9400DKB	BROWN
9400W	WHITE

PROJECT:
SUBMITTED BY:
DATE:
NOTES:

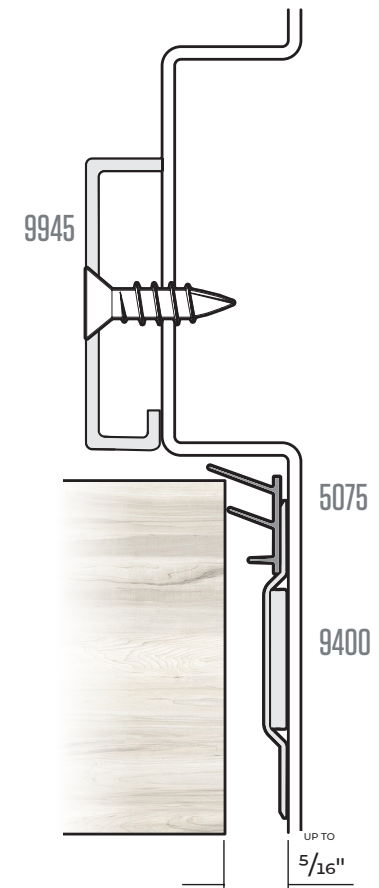

NGP-GAP-GAP90-PCS-0720-B

NGP MEMPHIS
4985 East Raines Road
Memphis, TN 38118
orders@ngp.com

NGP VEGAS
4584 Calimesa Street
Las Vegas, NV 89115
vegasorders@ngp.com

ngp.com
1-800-NGP-RUSH